



INSTRUCTION MANUAL

VHF MARINE TRANSCEIVER
IC-M503



Icom Inc.

IN CASE OF EMERGENCY

If your vessel requires assistance, contact other vessels and the Coast Guard by sending a distress call on Channel 16.

USING CHANNEL 16

DISTRESS CALL PROCEDURE

1. "MAYDAY MAYDAY MAYDAY."
2. "THIS IS" (name of vessel)
3. Your call sign or other indication of the vessel (AND 9-digit DSC ID if you have one).
4. "LOCATED AT" (your position)
5. The nature of the distress and assistance required.
6. Any other information which might facilitate the rescue.



Versions of the IC-M503 which display the "CE" symbol on the serial number seal, comply with the essential requirements of the European Radio and Telecommunication Terminal Directive 1999/5/EC.

Or, transmit your distress call using digital selective calling on Channel 70 (the optional DS-100 (#02) must be installed).

USING DIGITAL SELECTIVE CALLING (Ch 70)

(DS-100 (#02) DSC CONTROLLER is required)

DISTRESS CALL PROCEDURE

1. Push and hold [DISTRESS] on the DS-100 for 5 sec. until you hear 5 short beeps change to one long beep.
2. Wait for an acknowledgment from a coast station.
 - Channel 16 is automatically selected.
3. Push and hold [PTT], then transmit the appropriate information as at left.



This warning symbol indicates that this equipment operates in non-harmonised frequency bands and/or may be subject to licensing conditions in the country of use. Be sure to check that you have the correct version of this radio or the correct programming of this radio, to comply with national licensing requirements.

TABLE OF CONTENTS

IN CASE OF EMERGENCY	i
TABLE OF CONTENTS	ii
IMPORTANT	iii
CAUTIONS.....	iii
1 OPERATING RULES	1
2 PANEL DESCRIPTION	2–5
■ Panel description	2
■ Function display	4
■ Microphone	5
3 BASIC OPERATION	6–10
■ Channel selection	6
■ Receiving and transmitting	8
■ Call channel programming	9
■ Channel names	9
■ Optional voice scrambler operation ..	10
4 DUALWATCH/TRI-WATCH	11
■ Description	11
■ Operation	11
5 SCAN OPERATIONS	12–13
■ Scan types	12
■ Setting tag channels	13
■ Starting a scan	13
6 SET MODE	14–16
■ Set mode programming	14
■ Set mode items	15
7 INTERCOM OPERATION	17
■ Intercom operation	17
8 CONNECTIONS AND MAINTENANCE	18–24
■ Unpacking	18
■ Antenna	18
■ Fuse replacement	18
■ Cleaning	18
■ Connections	19
■ Microphone hanger	20
■ Mounting the transceiver	21
■ Optional unit installation	23
■ Dimensions	24
9 TROUBLESHOOTING	25
10 CHANNEL LIST	26
11 SPECIFICATIONS AND OPTIONS ...	27
■ Specifications	27
■ Options	27
12 HM-134 REMOTE-CONTROL MICROPHONE	28–38
■ Panel description	28
■ Function display	30
■ Channel selection	32
■ Receiving and transmitting	33
■ Lock functions	34
■ Display backlighting	34
■ Monitor function	34
■ Call channel programming	35
■ Optional voice scrambler operation.....	35
■ Starting a scan	36
■ Setting tag channels	36
■ Dualwatch/Tri-watch operation	36
■ Set mode programming	37
■ Intercom operation	38
■ Channel names	38
13 HM-134 CONNECTIONS AND INSTALLATION	39–41
■ HM-134 supplied accessories	39
■ Installation	39
MB-75 TEMPLATE INSTALLATION NOTES	

IMPORTANT

READ ALL INSTRUCTIONS carefully and completely before using the transceiver.

SAVE THIS INSTRUCTION MANUAL — This instruction manual contains important operating instructions for the IC-M503.

CAUTIONS

⚠ WARNING! NEVER connect the transceiver to an AC outlet. This may pose a fire hazard or result in an electric shock.

NEVER connect the transceiver to a power source of more than 15.6 V DC or using reverse polarity. This will ruin the transceiver.

NEVER cut the DC power cable between the DC plug and fuse holder. If an incorrect connection is made after cutting, the transceiver may be damaged.

NEVER place the transceiver where normal operation of the vessel may be hindered or where it could cause bodily injury.

KEEP the transceiver at least 1 m away from the ship's navigation compass.

DO NOT use or place the transceiver in areas with temper-

atures below -20°C or above $+60^{\circ}\text{C}$ or, in areas subject to direct sunlight, such as the cockpit.

AVOID the use of chemical agents such as benzine or alcohol when cleaning, as they may damage the transceiver surfaces.

BE CAREFUL! The transceiver rear panel will become hot when operating continuously for long periods.

BE CAREFUL! The optional HM-134 remote-control microphone's rear panel will become hot when monitoring continuously for long periods.

Place the transceiver in a secure place to avoid inadvertent use by children.

After exposure to salt water, clean the transceiver thoroughly with fresh water to avoid corrosion.

◇ PRIORITIES

- Read all rules and regulations pertaining to priorities and keep an up-to-date copy handy. Safety and distress calls take priority over all others.
- You must monitor Channel 16 when you are not operating on another channel.
- False or fraudulent distress signals are prohibited and punishable by law.

◇ PRIVACY

- Information overheard but not intended for you cannot lawfully be used in any way.
- Indecent or profane language is prohibited.

◇ RADIO LICENSES

(1) SHIP STATION LICENSE

You must have a current radio station license before using the transceiver. It is unlawful to operate a ship station which is not licensed.

Inquire through your dealer or the appropriate government agency for a Ship-Radiotelephone license application. This government-issued license states the call sign which is your ship's identification for radio purposes.

(2) OPERATOR'S LICENSE

A Restricted Radiotelephone Operator Permit is the license most often held by small ship radio operators when a radio is not required for safety purposes.

The Restricted Radiotelephone Operator Permit must be posted or kept with the operator. Only a licensed radio operator may operate a transceiver.

However, non-licensed individuals may talk over a transceiver if a licensed operator starts, supervises, ends the call and makes the necessary log entries.

Keep a copy of the current government rules and regulations handy.

■ Panel description

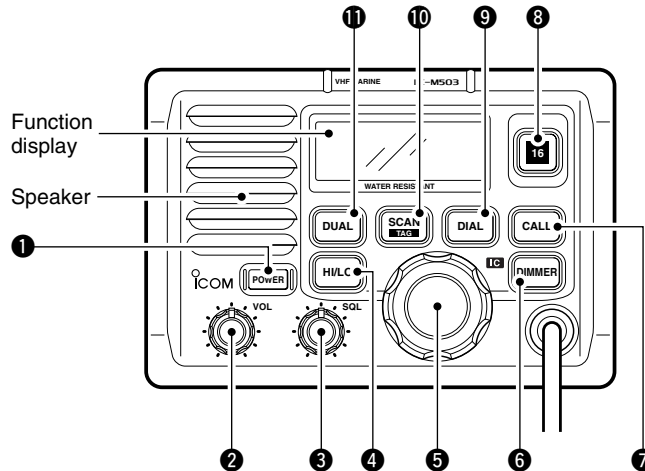

❶ POWER SWITCH [POWER]

Push to toggle the transceiver power ON and OFF.

❷ VOLUME CONTROL [VOL]

Adjusts the audio level. (p. 8)

❸ SQUELCH CONTROL [SQL]

Sets the squelch threshold level. (p. 8)

❹ TRANSMIT POWER SWITCH [HI/LO]

➤ Push to Toggle high and low power . (p. 8)

•Some channels are set to low power only.

➤ While pushing and holding this switch, other switches perform secondary functions.

5 CHANNEL SELECTOR [CHANNEL]

Rotate [CHANNEL] to select the operating channels, set mode contents, etc. (p. 8)

6 DIMMER SWITCH [DIMMER]

- ➔ Push to select one of 8 backlighting (LCD and switches) levels.
- ➔ Push and hold for 1 sec. to turn the intercom mode ON.

7 CALL CHANNEL SWITCH [CALL]

- ➔ Push to select the call channel. (p. 6)
- ➔ Push and hold for 3 sec. to enter call channel programming condition. (p. 9)
- ➔ While pushing and holding [HI/LO], enters memory name programming condition. (p. 9)

8 CHANNEL 16 SWITCH [16]

- ➔ Push to select Channel 16. (p. 6)
- ➔ While turning power ON, push to enter initial set mode. (p. 14)

9 DIAL SWITCH [DIAL]

- ➔ Push to exit from Channel 16 or call channel. (p. 6)
- ➔ While pushing and holding [HI/LO], push to select channel group. (pgs. 6, 7)
 - The “EUR” version has International channels only and this

function is not available.

10 SCAN SWITCH [SCAN/TAG] (p. 13)

- ➔ When tag channels are programmed, starts and stops normal or priority scan.
- ➔ Push and hold [SCAN/TAG] for 1 sec. to set the displayed channel as a tag (scanned) channel.
- ➔ While pushing and holding [HI/LO], push and hold for 3 sec. to clear all tag channels.

11 DUALWATCH/TRI-WATCH SWITCH [DUAL] (p. 11)

- ➔ Push to start dualwatch or tri-watch.
- ➔ When dualwatch/tri-watch is activated, push to stop them.

2 PANEL DESCRIPTION

■ Function display

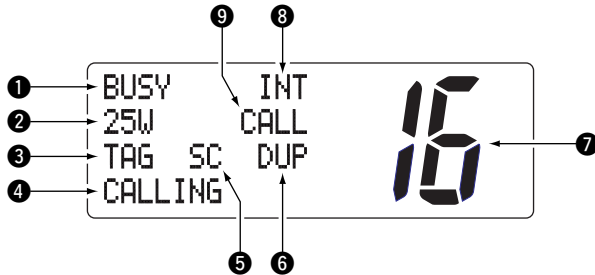

- 1 BUSY/TRANSMIT INDICATOR** (p. 8)
 - “BUSY” appears when receiving a signal or when the squelch opens.
 - “TX” appears while transmitting.
- 2 POWER INDICATOR** (p. 8)
 - “25W” appears when high power is selected.
 - “1W” appears when low power is selected.
- 3 TAG CHANNEL INDICATOR** (p. 13)

Appears when a tag channel is selected.
- 4 CHANNEL NAME INDICATOR**
 - Channel comment appears if programmed. (p. 9)
 - “Low Battery” appears when the battery voltage drops

to approx. 10 V DC or below.

- “DUAL” appears during dualwatch; “TRI” appears during tri-watch. (p. 11)
 - “WAIT” appears in the IC-M503 display while transmitting via the HM-134 remote-control microphone.
 - In the above case, the connected HM-134 has priority.
 - “LSTN” appears in the IC-M503 display when pushing the PTT switch on the HM-134, while the intercom function is activated.
- 5 SCRAMBLER INDICATOR** (p. 10)

Appears when the optional voice scrambler is activated.
 - 6 DUPLEX INDICATOR**

Appears when a duplex channel is selected.
 - 7 CHANNEL NUMBER READOUT**
 - Indicates the selected operating channel number. “A” appears when a simplex channel is selected. (p. 6)
 - In set mode, indicates the selected condition. (pgs. 15,16)
 - 8 CHANNEL GROUP INDICATOR** (p. 6)

Indicates whether an International, U.S.A., Holland, DSC or ATIS channel is selected.

 - Available channel groups depend on version.
 - 9 CALL CHANNEL INDICATOR** (pgs. 6, 9)

Appears when a call channel is selected.

■ Microphone

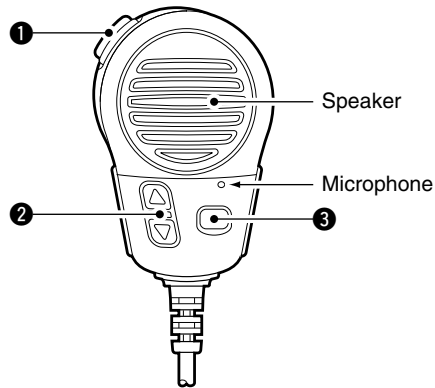

① PTT SWITCH [PTT]

Push and hold to transmit; release to receive. (p. 8)

② CHANNEL UP/DOWN SWITCHES [▲]/[▼]

Push either switch to change the operating memory channel, set mode contents, etc. (p. 8)

③ TRANSMIT POWER SWITCH [HI/LO]

- Same as the [HI/LO] switch on the front panel.
- When pushed at power ON, toggles the [▲]/[▼] and [HI/LO] switch functions ON and OFF.

■ Channel selection

◇ Channel 16

Channel 16 is the distress and safety channel. It is used for establishing initial contact with another station and for emergency communications. Channel 16 is monitored during both dualwatch and tri-watch. While standing by, you must monitor Channel 16.

➔ Push [16] to select Channel 16.

- Output power turns to “25W” automatically, whenever Channel 16 is selected. For example, when selecting Channel 16 via the dial, a scan stops at Channel 16 or [16•C] on the HM-134 is pushed, etc.

➔ Push [DIAL] to return to the condition before selecting Channel 16, or rotate [CHANNEL] to select operating channel.

- Output power returns to the previous output power automatically.

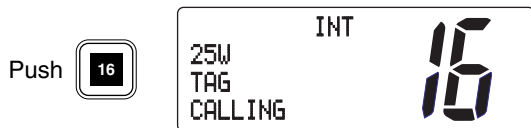

◇ Call channel

Each regular channel group has a separate leisure-use call channel. The call channel is monitored during tri-watch. The call channels can be programmed (p. 9) and are used to store your most often used channels in each channel group for quick recall.

➔ Push [CALL] to select the call channel of the selected channel group.

- “CALL” and call channel number appear.

➔ Push [DIAL] to return to the condition before selecting call channel, or rotate [CHANNEL] to select operating channel.

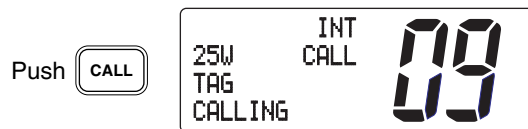

◇ International channels

There are 57 International channels for the IC-M503.

- ① Push [DIAL] to select a regular channel.
- ② While pushing and holding [HI/LO], push [DIAL] to change the channel group, if necessary.
 - “INT” appears when International channels are selected.
- ③ Rotate the channel selector to select a channel.
 - “DUP” appears for duplex channels.

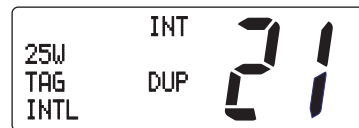

◇U.S.A. channels (U.K. version only)

For the U.K. versions, there are 58 U.S.A. channels in addition to 57 International channels.

- ① Push [DIAL] to select a regular channel.
- ② While pushing and holding [HI/LO], push [DIAL] to change the channel group.
 - International and U.S.A. channels can be selected in sequence.
- ③ Rotate the channel selector to select a channel.
 - Channels are memorized separately for each channel group.

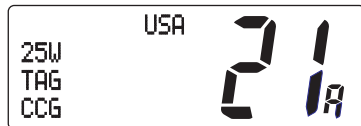

◇Holland channels (Holland version only)

For Holland versions, there are 59 Holland channels in addition to 57 International channels.

- ① Push [DIAL] to select a regular channel.
- ② While pushing and holding [HI/LO], push [DIAL] to change the channel group.
 - International and Holland channels can be selected in sequence.
- ③ Rotate the channel selector to select a channel.
 - Channels are memorized separately for each channel group.

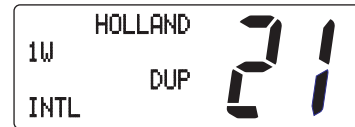

◇ATIS and DSC channels (FRG version only)

For the FRG versions, there are 57 ATIS and 57 DSC channels in addition to 57 International channels.

- ① Push [DIAL] to select a regular channel.
- ② While pushing and holding [HI/LO], push [DIAL] to change the channel group.
 - International, ATIS and DSC channels can be selected in sequence.
- ③ Rotate the channel selector to select a channel.
 - Channels are memorized separately for each channel group.

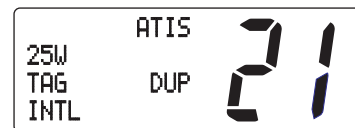

3 BASIC OPERATION

■ Receiving and transmitting

CAUTION: Transmitting without an antenna may damage the transceiver.

- ① Push [POWER] to turn power ON.
- ② Set the audio and squelch levels.
 - ➔ Rotate [SQL] fully counterclockwise in advance.
 - ➔ Rotate [VOL] to adjust the audio output level.
 - ➔ Rotate [SQL] clockwise until the noise disappears.
- ③ While pushing and holding [HI/LO], push [DIAL] to change the channel group. (p. 6)
 - The European version has International channels only.
- ④ Rotate the channel selector or push [▲]/[▼] on the microphone to select the desired channel.
 - When receiving a signal, “BUSY” appears and audio is emitted from the speaker.
 - Further adjustment of [VOL] may be necessary at this point.
 - Use the optional voice scrambler function for privacy. (p. 10)
- ⑤ Push [HI/LO] to select the output power if necessary.
 - “25W” or “1W” appears when high or low power is selected, respectively.
 - Choose low power to conserve power, choose high power for longer distance communications.
 - Some channels are for low power only.

- ⑥ Push and hold [PTT] to transmit, then speak into the microphone.
 - “TX” appears.
 - Channel 70 cannot be used for transmission (for GMDSS use).
- ⑦ Release [PTT] to receive.

IMPORTANT: To maximize the readability of your transmitted signal, pause a few sec. after pushing [PTT], hold the microphone 2 to 5 cm from your mouth and speak at a normal voice level.

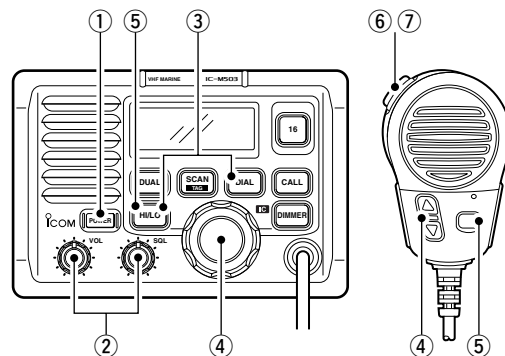

■ Call channel programming

The call channel switch can be programmed to your most often-used channels in each channel group for quick recall.

- ① While pushing and holding [HI/LO], push [DIAL] one or more times to select the desired channel group (International, U.S.A., Holland, ATIS, DSC) to be programmed.
- ② Push and hold [CALL] for 3 sec. to enter the call channel programming condition.
 - Channel number starts flashing.

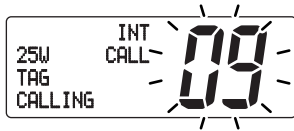

- ③ Rotate the channel selector to select the desired channel.

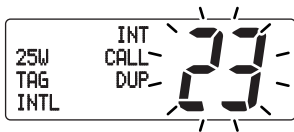

- ④ Push [CALL] to program the displayed channel as the call channel.
 - Push [DIAL] to cancel the programming.
 - The channel number stops flashing.

■ Channel names

Memory channels can be tagged with alphanumeric names of up to 10 characters each.

Capital letters, small letters, numerals, some symbols (! " # \$ % & ' () * + , - . /) and spaces can be used.

- ① Select the desired memory channel.
 - Cancel dual watch, tri-watch or scan in advance.
- ② While pushing and holding [HI/LO], push [CALL] to edit the memory channel name.
 - A cursor appears and blinks.



- ③ Select the desired character by rotating the channel selector or by pushing [▲]/[▼] on the microphone.
 - Push and hold [SCAN] or [DIAL] for cursor movement.
- ④ Push [CALL] to input and set the name.
 - The cursor disappears.
- ⑤ Repeat steps ① to ④ to program another memory channel name, if desired.

3 BASIC OPERATION

■ Optional voice scrambler operation

◆ Activating the scrambler

The optional voice scrambler provides private communications. In order to receive or send scrambled transmissions you must first activate the scrambler function. To activate the function, an optional UT-98 or UT-112 is necessary. See p. 16 for selecting the unit. Ask your dealer for details.

- ① Select an operating channel other than Channel 16 and 70.
- ② While pushing and holding [HI/LO], push [DIMMER] to toggle an optional scrambler function ON or OFF.
 - “SC” appears.
- ③ To turn the scrambler function OFF, repeat step ②.
 - “SC” disappears.

◆ Programming scrambler codes

There are 128 or 32 codes (0 to 127 or 1 to 32) available for programming. In order to understand one another, all transceivers in your group must have the same scramble code.

This function may not be available depending on dealer setting.

- ① Turn power OFF.
- ② While pushing and holding [16], turn power ON to enter set mode.
- ③ After the display appears, release [16].
- ④ Push [16] one or more times to select the scrambler code item.
 - “Scrambler code” appears.
- ⑤ Rotate the channel selector to select the desired scrambler code.
- ⑥ Turn power OFF, then ON again to exit set mode.

[Example]: Programming scrambler code 127.

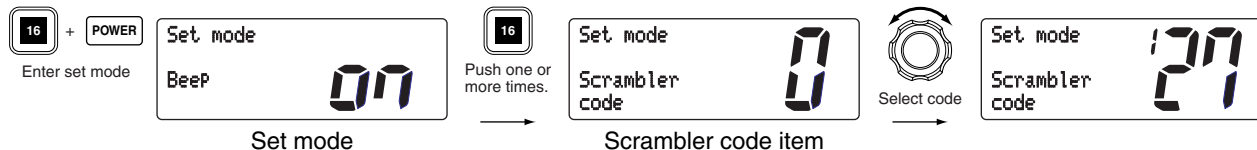

■ Description

Dualwatch monitors Channel 16 while you are receiving another channel; tri-watch monitors Channel 16 and the call channel while receiving another channel.

DUALWATCH/TRI-WATCH SIMULATION

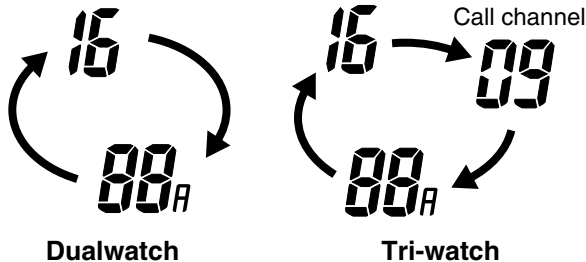

- If a signal is received on Channel 16, dualwatch/tri-watch pauses on Channel 16 until the signal disappears.
- If a signal is received on the call channel during tri-watch, tri-watch becomes dualwatch until the signal disappears.
- To transmit on the selected channel during dualwatch/tri-watch, push and hold [PTT].

■ Operation

- ① Select the desired operating channel.
- ② Select dualwatch or tri-watch in set mode. (p. 15)
- ③ Push [DUAL] to start dualwatch or tri-watch.
 - “DUAL” appears during dualwatch; “TRI” appears during tri-watch.
 - Beep tone sounds when a signal is received on Channel 16.
 - Tri-watch becomes dualwatch when receiving a signal on the call channel.
- ④ To cancel dualwatch/tri-watch, push [DUAL] again.

[Example]: Operating tri-watch on INT Channel 25.

25W TAG TRI	INT DUP 16	25	Tri-watch starts.
BUSY 25W TAG CALLING	INT CALL 16	09	Signal is received on call channel.
BUSY 25W TAG CALLING	INT DUP 16	25	Signal received on Channel 16 takes priority.
25W TAG TRI	INT DUP 16	25	Tri-watch resumes after the signal disappears.

■ Scan types

Scanning is an efficient way to locate signals quickly over a wide frequency range. The transceiver has priority scan and normal scan.

Set the tag channels (scanned channel) before scanning. Clear the tag channels which inconveniently stop scanning, such as those for digital communication use.

/// Choose priority scan or normal scan in set mode in advance. (p. 15)

PRIORITY SCAN

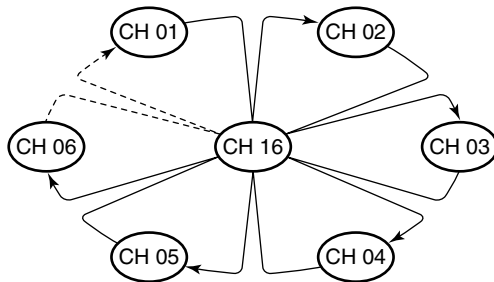

Priority scan searches through all tag channels in sequence while monitoring Channel 16. When a signal is detected on Channel 16, scan pauses until the signal disappears; when a signal is detected on a channel other than Channel 16, scan becomes dualwatch until the signal disappears.

NORMAL SCAN

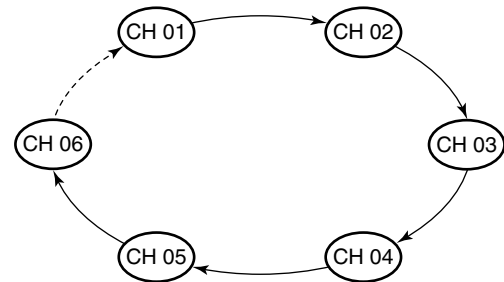

Normal scan, like priority scan, searches through all tag channels in sequence. However, unlike priority scan, Channel 16 is not checked unless Channel 16 is set as a tag channel.

■ Setting tag channels

For more efficient scanning, add desired channels as tag channels or clear tag channels that are unwanted channels. Channels set as non-tag channels will be skipped during scanning. Tag channels can be assigned to each channel group (International, U.S.A., Holland, DSC, ATIS) independently.

- ① While pushing and holding [HI/LO], push [DIAL] one or more times to select the desired channel group, if desired.
- ② Select the desired channel to set as a tag channel.
- ③ Push and hold [SCAN/TAG] for 1 sec. to set the displayed channel as a tag channel.
 - “TAG” appears in the function display.
- ④ To cancel the tag channel setting, repeat ③.
 - “TAG” disappears.

•Clearing all tag channels in the selected channel group

➤ While pushing and holding [HI/LO], push and hold [DIAL]

for 3 sec. to clear all tag channels in the channel group.

■ Starting a scan

Set scan type (priority or normal scan) and scan resume timer in advance using set mode. (p. 15)

- ① Set tag channels as described at left.
- ② While pushing and holding [HI/LO], push [DIAL] one or more times to select the desired channel group, if desired.
- ③ Push [SCAN] to start priority or normal scan.
 - “Pri scan 16” or “Normal scan” appears in the function display.
 - When a signal is detected, scan pauses until the signal disappears or resumes after pausing 5 sec. according to set mode setting. (Channel 16 is still monitored during priority scan.)
 - Rotate the channel selector to check the scanning tag channels, to change the scanning direction or resume the scan manually.
 - “16” flashes and a beep tone sounds when a signal is received on Channel 16 during priority scan.
- ④ To stop the scan, push [SCAN].
 - “Pri scan” or “Normal scan” disappears.

[Example]: Starting a normal scan.

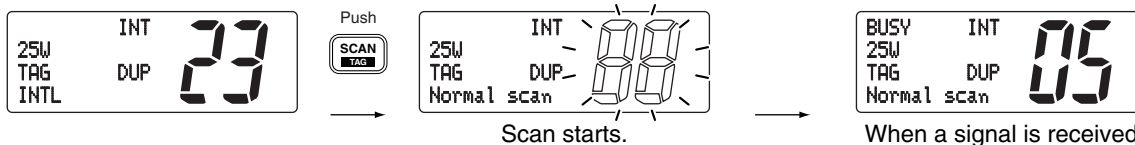

■ Set mode programming

Set mode is used to change the conditions of the transceiver's functions: scan mode (normal or priority), scan resume timer, dualwatch/tri-watch selection, beep tone function (transceiver or HM-134), internal speaker (transceiver or HM-134), LCD contrast (transceiver or HM-134), scrambler code, scrambler type and ATIS check.

- ▨ Available functions may differ depending on dealer setting.
- ▨ The optional HM-134 has it's own settings for the beep tone, internal speaker and LCD contrast.

- ① Turn power OFF.
- ② While pushing and holding [16], turn power ON to enter set mode.
- ③ After the display appears, release [16].
- ④ Push [16] to select the desired item, if necessary.
- ⑤ Rotate the channel selector to select the desired condition of the item.
- ⑥ Turn power OFF, then ON again to exit set mode.

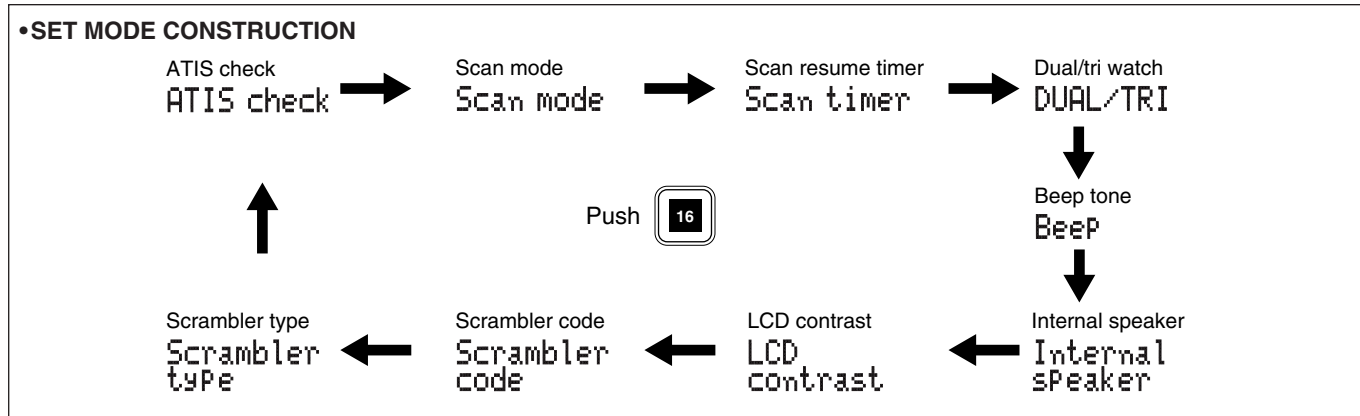

■ Set mode items

◇ Scan mode

The transceiver has 2 scan modes: normal scan and priority scan. Normal scan searches all tag channels in the selected channel group. Priority scan searches all tag channels in sequence while monitoring channel 16.



Priority scan (default)



Normal scan

◇ Scan resume timer

The scan resume timer can be selected as a pause (OFF) or timer scan (ON). When OFF is selected, the scan pauses until the signal disappears. When ON is selected, the scan pauses 5 sec. and resumes even if a signal is being received on channels, except for Channel 16.

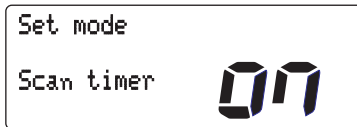

Scan timer ON (default)



Scan timer OFF

◇ Dual/tri watch

This item sets the [DUAL] switch function as dual watch or tri-watch.

See the section 'Dual watch/Tri-watch' for details.

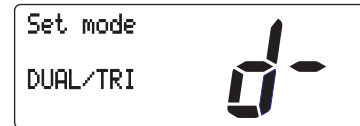

Dual watch (default)



Tri-watch

◇ Beep tone

You can select silent operation by turning beep tones OFF or you can have confirmation beeps sound at the push of a switch by turning beep* tones ON.



Beep tone ON (default)



Beep tone OFF

*Beep tones setting are selectable on IC-M503 and HM-134 independently

6 SET MODE

◆ Internal speaker

When an optional external speaker is connected, the speakers on the transceiver and microphone can be muted.



Internal speaker ON (default)

Internal speaker OFF

*Internal speaker setting is selectable on IC-M503 and HM-134 independently

◆ LCD contrast

This item adjusts the contrast of the LCD in 8 steps.

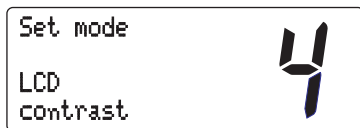

LCD contrast 4 (default)

*LCD contrast setting is adjustable on IC-M503 and HM-134 independently

◆ Scrambler code

When an optional scrambler unit is connected, the scrambler code can be set depending on dealer setting.

When the UT-98 or UT-112 is installed, 128 or 32 codes (0 to 127 or 1 to 32) can be selected, respectively.



Scrambler code 0 (UT-98 default)

Scrambler code 127

◆ Scrambler type

When an optional scrambler unit is connected, the scrambler unit can be selected in set mode depending on dealer setting.



UT-98 scrambler unit

UT-112 scrambler unit

◆ ATIS check

The ATIS ID code can be checked in set mode.

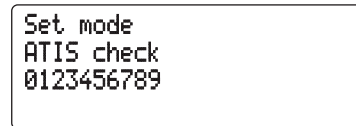

ATIS code

■ Intercom operation

The optional intercom function allows you to talk to the deck from the cabin. The optional HM-134* REMOTE-CONTROL MICROPHONE is required for intercom operation.

***DO NOT** connect another remote-control microphone.

Connect an optional HM-134 as described on p. 39.

- Transmitting is impossible during intercom operation.
- The received signal is muted during intercom operation.

- ① Push and holding [DIMMER] for 1 sec. to enter intercom mode.
 - The HM-134 power is automatically turned ON, even if the power is OFF.

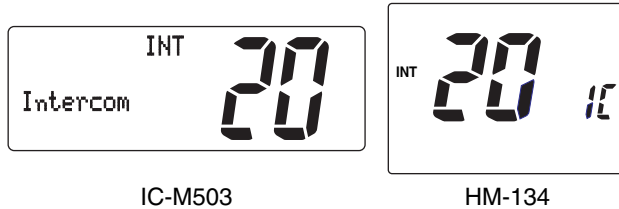

- ② Push and hold [DIMMER] again to call up.
 - The transceiver and microphone emit call beeps.
- ③ Push and hold the PTT switch and speak at a normal voice level into the microphone.
 - “TALK” or “LSTN” appears on the caller or listener function display, respectively.

- To adjust the IC-M503’s speaker output level, rotate [VOL].
- To adjust the HM-134’s speaker output level, push [▲]/[▼] after pushing [VOL].

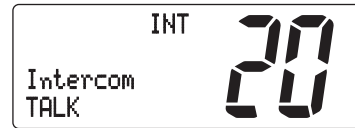

IC-M503 (caller)



HM-134 (listener)

- ④ After releasing the PTT switch you can hear the response through the speaker.
 - ⑤ To return to normal operation, push [DIMMER] momentarily.
 - Other switches also turn the function OFF, however, the corresponding function is then activated e.g. pushing [16] selects Channel 16.
- ▨ • While in the intercom mode, the transceiver functions (transmit and receive) are interrupted. If the transceiver is in transmit condition, the intercom function is not available.

■ Unpacking

The following accessories are supplied: Qty.

① Mounting bracket	1
② DC power cable (OPC-891)	1
③ Microphone hanger	1
④ Microphone hanger cable* (OPC-1096 : Black)	1
⑤ Mounting bracket knobs	2
⑥ Microphone hanger screws (3 × 16 mm)	2
⑦ Mounting screws (5 × 20 mm)	2
⑧ Flat washers (M5)	2
⑨ Spring washers (M5)	2

*Depending on version.

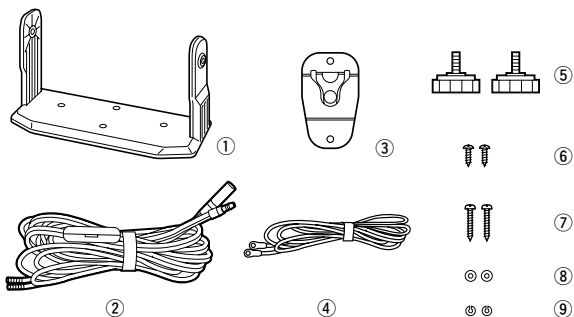

■ Antenna

A key element in the performance of any communication system is an antenna. Ask your dealer about antennas and the best places to mount them.

■ Fuse replacement

Two fuses are installed in the supplied DC power cable. If a fuse blows or the transceiver stops functioning, track down the source of the problem, if possible, and replace the damaged fuse with a new, rated one.

■ Cleaning

If the transceiver becomes dusty or dirty, wipe it clean with a soft, dry cloth.



AVOID the use of solvents such as benzene or alcohol, as they may damage transceiver surfaces.

■ Connections

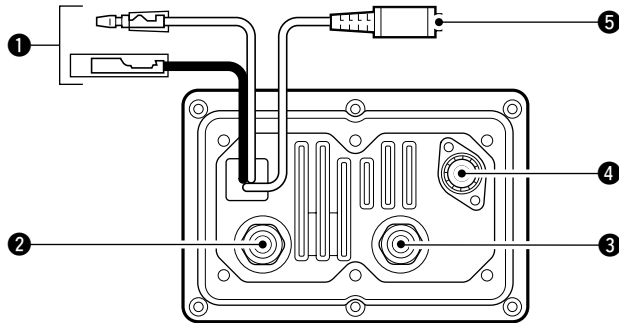

① DC POWER CONNECTOR

Connects the supplied DC power cable from this connector to an external 12 V DC power source.

CAUTION: After connecting the DC power cable and external speaker jack, cover the connector and jack as shown below to avoid water seeping into the transceiver.

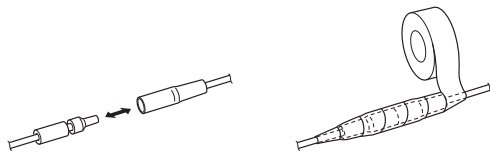

② EXTENSION JACK

Connects to the optional DS-100 (#02) DSC CONTROLLER.

③ EXTERNAL MICROPHONE CONNECTOR

Connects to the optional **HM-134** REMOTE-CONTROL MICROPHONE.

- Intercom function is available.

CAUTION: NEVER connect another microphone such as the HM-127, etc. It may cause damage to the transceiver.

④ ANTENNA CONNECTOR

Connects a marine VHF antenna with a PL-259 connector to the transceiver.

CAUTION: Transmitting without an antenna may damage the transceiver.

⑤ EXTERNAL SPEAKER JACK

Connects to an external speaker. See 'Options' on p. 27 for available external speakers.

■ Microphone hanger

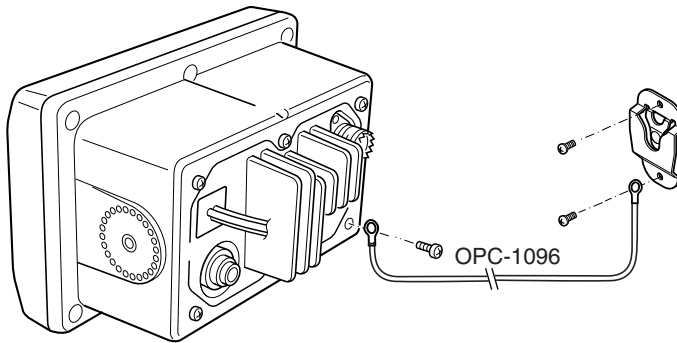

Rest the supplied microphone on the hanger when not in use. Connect the OPC-1096* to the transceivers chassis and microphone hanger to use the microphone hanger function.

* Depending on version.

- Tighten the screw at fixing torque $0.7 \text{ N} \cdot \text{m}$ ($6.9 \text{ kg} \cdot \text{m}$).
- If the microphone hanger function is used, Channel 16 is selected automatically when the supplied microphone is rested on the hanger.

■ Mounting the transceiver

◆ Using the supplied mounting bracket

The universal mounting bracket supplied with your transceiver allows overhead or dashboard mounting.

- Mount the transceiver securely with the 2 screws supplied (M5 × 20) to a surface which is more than 10 mm thick and can support more than 5 kg.
- Mount the transceiver so that the face of the transceiver is at 90° to your line of sight when operating it.

/// **CAUTION:** KEEP the transceiver and microphone at least 1 meter away from your ship's magnetic navigation compass.

/// **NOTE:** Check the installation angle; the function display may not be easy-to-read at some angles.

• OVERHEAD MOUNTING

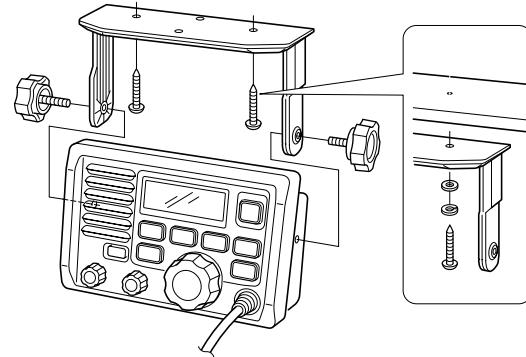

• MOUNTING ON DASHBOARD

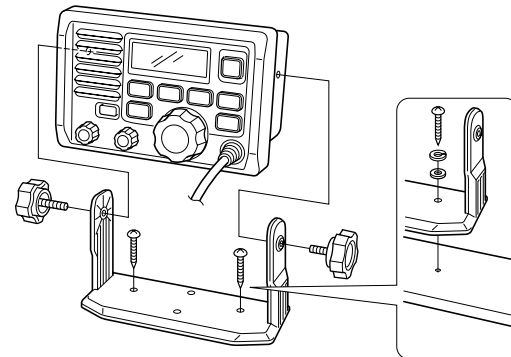

8 CONNECTIONS AND MAINTENANCE

◆ Using the optional mounting bracket

An optional MB-75 FLUSH MOUNT is available for mounting the transceiver to a flat surface such as an instrument panel.

CAUTION: KEEP the transceiver and microphone at least 1 meter away from your ship's magnetic navigation compass.

- ① Using the template on the last page, carefully cut a hole into the instrument panel (or wherever you plan to mount the controller).
- ② Slide the transceiver through the hole as shown below.

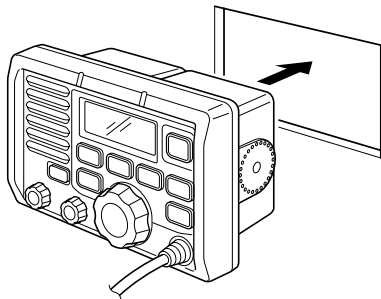

- ③ Attach the 2 bolts supplied (M5 × 8 mm) on either side of the IC-M503.

- ④ Attach the clamps on either side of the transceiver.
 - Make sure that the clamps align parallel to the transceiver body.

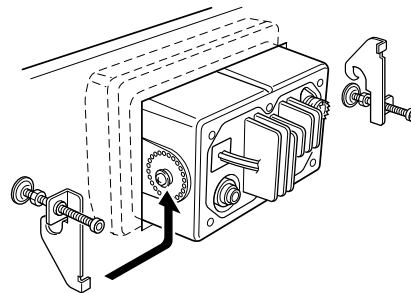

- ⑤ Tighten the end bolts on the clamps (rotate clockwise) so that the clamps press firmly against the inside of the instrument control panel.
- ⑥ Tighten the locking nuts (rotate counterclockwise) so that the transceiver is securely mounted in position as below.
- ⑦ Connect the antenna and control cable, then return the instrument control panel to its original place.

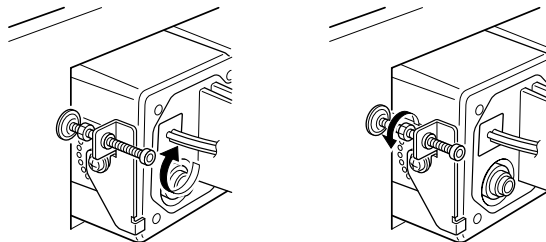

■ Optional unit installation

CAUTION: DISCONNECT the DC power cable from the transceiver before performing any work on the transceiver. Otherwise, there is danger of electric shock and/or equipment damage.

◆ Opening the transceiver case

Follow the case opening procedure shown here when you want to install an optional unit, etc.

- ① Remove the 6 screws as shown below and open the transceiver.

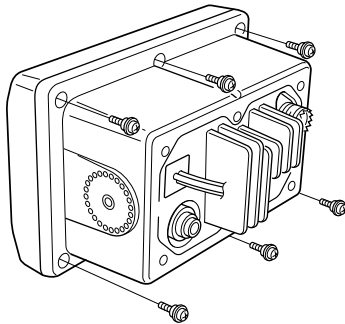

- ② Remove the 4 screws from the shielding plate, then lift up the shielding plate.
- ③ Plug an optional unit to the MAIN unit as shown below.

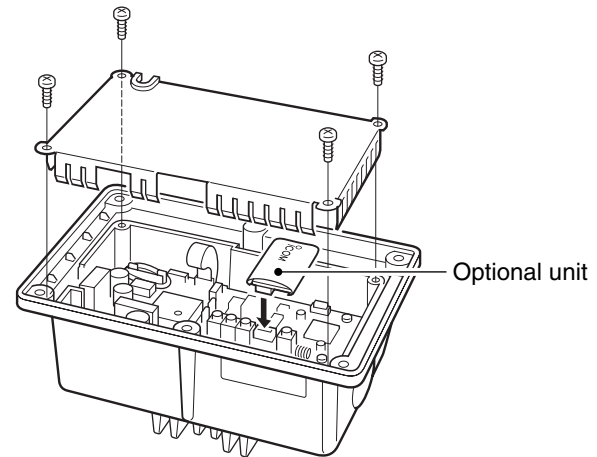

- ④ Return the shielding plate and assemble the units to their original positions.

8 CONNECTIONS AND MAINTENANCE

■ Dimensions

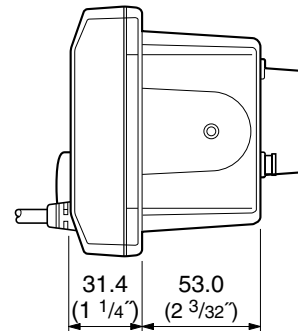
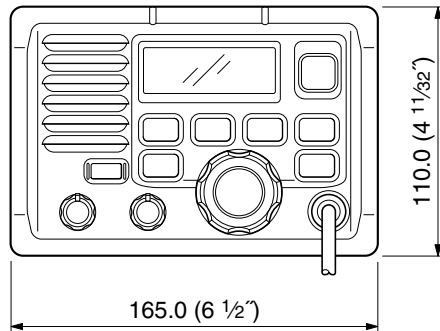
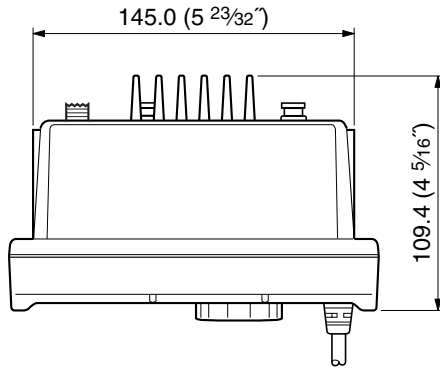

Unit: mm (inch)

PROBLEM	POSSIBLE CAUSE	SOLUTION	REF.
No power comes ON.	<ul style="list-style-type: none"> •Bad connection to the power supply. 	<ul style="list-style-type: none"> •Check the connection to the transceiver. 	p. 19
No sound comes from the speaker.	<ul style="list-style-type: none"> •Squelch level is too deep. •Volume level is too low. •Speaker has been exposed to water. 	<ul style="list-style-type: none"> •Set squelch to the threshold point. •Set [VOL] to a suitable level. •Drain water from the speaker. 	<p>p. 8</p> <p>p. 8</p> <p>—</p>
Transmitting is impossible, or high power cannot be selected.	<ul style="list-style-type: none"> •Some channels are for low power or receive only. •The output power is set to low. 	<ul style="list-style-type: none"> •Change channels. •Push [HI/LO] to select high power. 	<p>pgs. 6, 26</p> <p>p. 8</p>
Scan does not start.	<ul style="list-style-type: none"> •“TAG” channel is not programmed. 	<ul style="list-style-type: none"> •Set the desired channels as “TAG” channels. 	p. 13
No beep sounds.	<ul style="list-style-type: none"> •Beep tone is turned OFF. 	<ul style="list-style-type: none"> •Turn the beep tone ON in SET mode. 	p. 15
Receive signal cannot be understood.	<ul style="list-style-type: none"> •Optional voice scrambler is turned OFF. •Scramble code is not set correctly. 	<ul style="list-style-type: none"> •Turn the optional voice scrambler ON. •Reset the scramble code. 	<p>p. 10</p> <p>p. 16</p>

10 CHANNEL LIST

• International channels

CH	Frequency (MHz)		CH	Frequency (MHz)		CH	Frequency (MHz)		CH	Frequency (MHz)		CH	Frequency (MHz)		CH	Frequency (MHz)	
	Transmit	Receive		Transmit	Receive		Transmit	Receive		Transmit	Receive		Transmit	Receive		Transmit	Receive
01	156.050	160.650	11	156.550	156.550	21	157.050	161.650	62	156.125	160.725	72	156.625	156.625	82	157.125	161.725
02	156.100	160.700	12	156.600	156.600	22	157.100	161.700	63	156.175	160.775	73	156.675	156.675	83	157.175	161.775
03	156.150	160.750	13	156.650	156.650	23	157.150	161.750	64	156.225	160.825	74	156.725	156.725	84	157.225	161.825
04	156.200	160.800	14	156.700	156.700	24	157.200	161.800	65	156.275	160.875	75 [†]	156.775	156.775	85	157.275	161.875
05	156.250	160.850	15 [†]	156.750	156.750	25	157.250	161.850	66	156.325	160.925	76 [†]	156.825	156.825	86	157.325	161.925
06	156.300	156.300	16	156.800	156.800	26	157.300	161.900	67	156.375	156.375	77	156.875	156.875	87	157.375	157.375
07	156.350	160.950	17 [†]	156.850	156.850	27	157.350	161.950	68	156.425	156.425	78	156.925	161.525	88	157.425	157.425
08	156.400	156.400	18	156.900	161.500	28	157.400	162.000	69	156.475	156.475	79	156.975	161.575			
09	156.450	156.450	19	156.950	161.550	60	156.025	160.625	70 [†]	156.525	156.525	80	157.025	161.625			
10	156.500	156.500	20	157.000	161.600	61	156.075	160.675	71	156.575	156.575	81	157.075	161.675			

• USA channels (for U.K. version only)

CH	Frequency (MHz)		CH	Frequency (MHz)		CH	Frequency (MHz)		CH	Frequency (MHz)		CH	Frequency (MHz)		CH	Frequency (MHz)	
	Transmit	Receive		Transmit	Receive		Transmit	Receive		Transmit	Receive		Transmit	Receive		Transmit	Receive
01A	156.050	156.050	12	156.600	156.600	22A	157.100	157.100	64A	156.225	156.225	77	156.875	156.875	86	157.325	161.925
--	---	---	13 [†]	156.650	156.650	23A	157.150	157.150	65A	156.275	156.275	78A	156.925	156.925	86A	157.325	157.325
03A	156.150	156.150	14	156.700	156.700	24	157.200	161.800	66A	156.325	156.325	79A	156.975	156.975	87	157.375	161.975
--	---	---	15 [†]	156.750	156.750	25	157.250	161.850	67 [†]	156.375	156.375	80A	157.025	157.025	87A	157.375	157.375
05A	156.250	156.250	16	156.800	156.800	26	157.300	161.900	68	156.425	156.425	81A	157.075	157.075	88	157.425	162.025
06	156.300	156.300	17 [†]	156.850	156.850	27	157.350	161.950	69	156.475	156.475	82A	157.125	157.125	88A	157.425	157.425
07A	156.350	156.350	18A	156.900	156.900	28	157.400	162.000	70 [†]	156.525	156.525	83A	157.175	157.175			
08	156.400	156.400	19A	156.950	156.950	37A	157.850	157.850	71	156.575	156.575	84	157.225	161.825			
09	156.450	156.450	20	157.000	161.600	61A	156.075	156.075	72	156.625	156.625	84A	157.225	157.225			
10	156.500	156.500	20A	157.000	157.000	--	---	---	73	156.675	156.675	85	157.275	161.875			
11	156.550	156.550	21A	157.050	157.050	63A	156.175	156.175	74	156.725	156.725	85A	157.275	157.275			

[†]Low power only.

[†]Receive only.

■ Specifications

• GENERAL

- Frequency coverage :
 - Transmit 156.000–161.450 MHz
 - Receive 156.000–163.425 MHz
- Mode : FM (16K0G3E)
- Channel spacing : 25 kHz
- Current drain (at 13.8 V) : TX high 6.0 A max.
Max. audio 1.5 A max.
- Power supply requirement : 13.8 V DC (10.8 to 15.6 V)
- Frequency stability : ± 10 ppm (-20°C to $+60^{\circ}\text{C}$)
- Dimensions : 165(W) \times 110(H) \times 109.4(D) mm
(Projection not included)
- Weight : 1130 g

• TRANSMITTER

- Output power : 25 W and 1 W
- Modulation system : Variable reactance phase modulation
- Max. frequency deviation : ± 5.0 kHz
- Spurious emissions : Less than 0.25 μW

• RECEIVER

- Receive system : Double conversion superheterodyne
- Sensitivity (20 dB SINAD) : Less than $-3\text{dB}\mu$ EMF (typical)
- Squelch sensitivity : Less than $0\text{dB}\mu$ EMF
- Intermodulation rejection ratio : More than 68 dB
- Spurious response rejection ratio : More than 70 dB
- Adjacent channel selectivity : More than 70 dB
- Audio output power :
 - IC-M503 2 W at 10% distortion with a 4 Ω load
 - HM-134 2 W at 10% distortion with a 8 Ω load

■ Options

• DS-100 (#02) DSC CONTROLLER

When the DS-100 is installed, the transceiver conforms to DSC Class D for marine digital communications.

• MB-75 FLUSH MOUNT

For mounting the transceiver to a panel.

• HM-134 REMOTE-CONTROL MICROPHONE

External microphone-type controller. Provides optional intercom operation. 6 m (20 feet) microphone cable and mounting base included. Black color is available.

• OPC-999 MICROPHONE EXTENSION CABLE

6 m (20 feet) microphone extension cable for optional HM-134. Up to 2 OPC-999 can be connected. (18 m; 60 feet maximum)

• SP-5 EXTERNAL SPEAKER (IC-M503 ONLY)

A large, external speaker for superior audio output.

• SP-10 EXTERNAL SPEAKER (IC-M503 ONLY)

A compact, external speaker. Features easy installation.

• UT-98 VOICE SCRAMBLER UNIT

• UT-112 VOICE SCRAMBLER UNIT

Ensures private communications. 128 or 32 codes are available. Not available in some countries.

All stated specifications are subject to change without notice or obligation.

■ Panel description

The optional HM-134 remotely controls the IC-M503 and provides an optional intercom function.

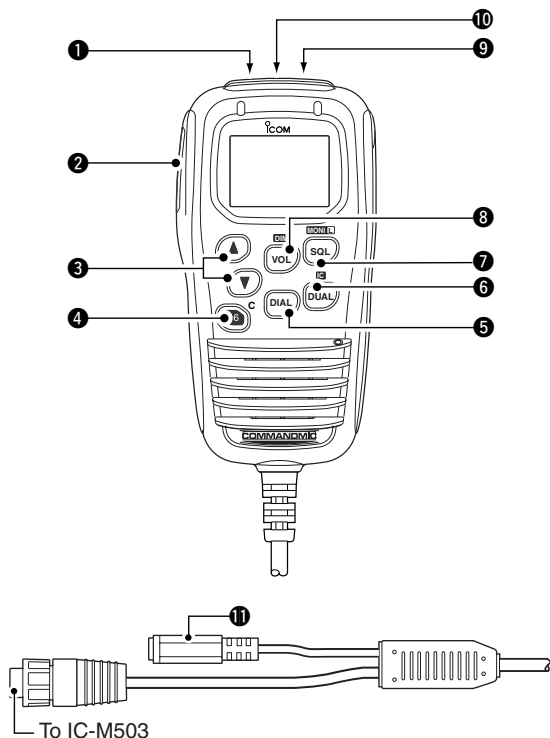

❶ POWER SWITCH [PWR] (pgs. 8, 33)

When the IC-M503 power is turned ON, push and hold for 2 sec. to turn the HM-134 power ON or OFF.

❷ PTT SWITCH [PTT] (pgs. 8, 33)

Push and hold to transmit; release to receive.

❸ CHANNEL UP/DOWN SWITCHES [▲]/[▼]

➤ Push either switch to change the operating channel, set mode contents, etc. (pgs. 8, 33)

➤ While pushing and holding [VOL], push [▲]/[▼] to adjust the brightness of the LCD and switch backlight. (p. 34)

➤ After [VOL] or [SQL] is pushed, push either switch to adjust audio level or noise squelch level, respectively. (pgs. 8, 33)

➤ In set mode, changes setting of the selected item. (pgs. 9, 37)

➤ During scanning, checks tag channels or changes scanning direction. (pgs. 8, 36)

❹ CHANNEL 16/CALL CHANNEL SWITCH [16•C]

➤ When pushed, selects Channel 16. (pgs. 6, 32)

➤ When pushed and held for 1 sec., selects call channel. (pgs. 6, 32)

•“CALL” appears when call channel is selected.

➤ When call channel is selected, push and hold for 3 sec. to enter call channel programming condition. (pgs. 9, 35)

➤ While pushing and holding [H/L], enters memory name programming condition. (pgs. 9, 38)

➔ Enter set mode when pushed and held while turning power ON. (pgs. 14, 37)

5 DIAL SWITCH [DIAL]

- ➔ Selects and toggles the regular channels when pushed momentarily. (pgs. 6, 7, 32)
- ➔ While pushing and holding [H/L], push to select channel group. (pgs. 6, 7 and 32)
 - The “ EUR ” version has International channels only and this function is not available.

6 DUAL-WATCH/INTERCOM SWITCH [DUAL•IC]

- ➔ Push to start dualwatch or tri-watch. (pgs. 11, 36)
- ➔ Push and hold for 1 sec. to activate the intercom function. (pgs. 17, 38)
- ➔ Push to stop dualwatch or tri-watch when either is activated.
- ➔ While pushing and holding the switch, you can call the IC-M503 in intercom mode. (pgs. 17, 38)

7 SQUELCH/MONITOR/LOCK SWITCH [SQL•MONI•L]

- ➔ After pushing [SQL], [▲]/[▼] sets the squelch threshold level. (p. 33)
- ➔ Push and hold [SQL•MONI] for 1 sec. to turn the monitor function ON. (p. 34)
- ➔ While pushing and holding [H/L], push [SQL•MONI•L] to toggle the microphone key lock function ON or OFF. (p. 34)
 - “  ” appears while key lock function is in use.
 - [PWR], [PTT], [VOL], [SQL] and [H/L] still function when the

microphone key lock function is turned ON.

- ➔ Advances the cursor while in memory name programming condition. (pgs. 9, 38)

8 VOLUME/DIMMER SWITCH [VOL•DIM]

- ➔ After pushing [VOL], [▲]/[▼] adjusts the audio level.
- ➔ Push and hold [VOL•DIM] for 1 sec. to adjust the brightness of the LCD and switch backlight. (p. 34)
- ➔ Moves the cursor backward while in memory name programming condition. (pgs. 9, 38)

9 TRANSMIT POWER SWITCH [H/L]

- ➔ When pushed, toggles high and low power. (pgs. 8, 33)
 - Some channels are set to low power only.
- ➔ While pushing and holding this switch, other switches perform secondary functions.
- ➔ Toggles the all key lock function ON or OFF when pushed and held while turning power ON. (p. 34)
 - “  ” flashes while the all key lock function is in use.
 - Only [PWR] and [PTT] function when the all key lock function is in use.

10 SCAN SWITCH [SCAN•TAG] (pgs. 13, 36)

- ➔ Starts and stops normal or priority scan when tag channels are programmed.
- ➔ Push and hold [SCAN•TAG] for 1 sec. to set the displayed channel as a tag (scanned) channel.
- ➔ While pushing and holding [H/L], push and hold for 3 sec. to clear all tag channels.

12 HM-134 REMOTE-CONTROL MICROPHONE

11 EXTERNAL SPEAKER JACK

- Connect the external speaker (an 8 Ω load). The internal speaker can be deactivated via the Set mode programming. (p. 37)
- The speaker output employs a BTL (Balanced Trans-Less) circuit, **NEVER** connect the speaker cable to ground (or chassis). Use a floating setup.

CAUTION: After connecting the external speaker jack, cover the jack with water resistant tape as shown below to avoid water seeping into the microphone. Binding the mic-cable and external-speaker jack connection mold with water resistant tape increases the water-proofing of the connection mold.

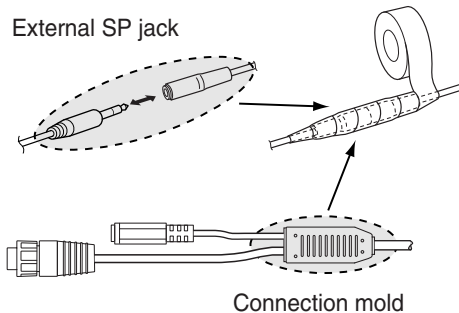

Function display

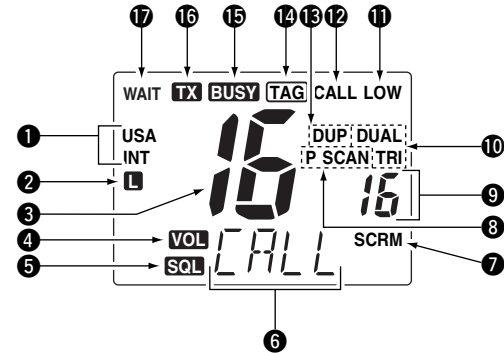

- 1 CHANNEL GROUP INDICATOR** (pgs. 6, 32)
Indicates whether an International (INT) or U.S.A. (USA) channel is selected.
- 2 KEY LOCK INDICATOR** (p. 34)
 - Appears while the key lock function is in use.
 - Flashes while the all key lock function is in use.
- 3 CHANNEL NUMBER READOUT**
 - Indicates the selected operating channel number. "A" appears when a simplex channel is selected. (pgs. 6, 32)

- ➔ In set mode, indicates the selected condition. (pgs. 14, 37)
- ④ VOLUME INDICATOR** (p. 33)
Appears while audio output level is adjusted.
- ⑤ SQUELCH INDICATOR** (p. 33)
Appears while noise squelch level is adjusted.
- ⑥ CHANNEL NAME INDICATOR**
 - ➔ Channel comment appears (and scrolls) if programmed. (pgs. 9, 38)
 - ➔ In set mode, indicates or scrolls the selected set mode item. (pgs. 14, 37)
- ⑦ SCRAMBLER INDICATOR** (pgs. 10, 35)
Appears when an optional voice scrambler is activated.
- ⑧ SCAN INDICATOR** (pgs. 13, 36)
 - ➔ “SCAN” appears during normal scan.
 - ➔ “P SCAN” appears during priority scan.
- ⑨ PRIORITY CHANNEL INDICATOR**
 - ➔ Indicates a priority channel during priority scan or dual/tri-watch. (pgs. 12, 36)
 - ➔ “IC” appears during intercom mode. (pgs. 17, 38)
- ⑩ DUAL/TRI WATCH INDICATOR** (pgs. 11, 36)
“DUAL” appears during dualwatch; “TRI” during tri-watch.
- ⑪ LOW POWER INDICATOR** (pgs. 8, 33)
Appears when low power is selected.
- ⑫ CALL CHANNEL INDICATOR** (pgs. 6, 32)
Appears when the call channel is selected.
- ⑬ DUPLEX INDICATOR** (pgs. 6, 32)
Appears when a duplex channel is selected.
- ⑭ TAG CHANNEL INDICATOR** (pgs. 13, 36)
Appears when a tag channel is selected.
- ⑮ BUSY INDICATOR** (pgs. 8, 33, 34)
Appears when receiving a signal or when the squelch opens.
- ⑯ TRANSMIT INDICATOR** (pgs. 8, 33)
Appears while transmitting.
- ⑰ “WAIT” INDICATOR**
“WAIT” appears in the HM-134 display while transmitting via the IC-M503’s attached microphone.
 - In the above case, the connected HM-134 does not have priority.

■ Channel selection

◇ Channel 16

- ① Push [16•C] to select Channel 16.
- ② Push [DIAL] to return to the condition before selecting Channel 16, or push [▲] or [▼] to select operating channel.
 - Output power turns to “25W” automatically, whenever Channel 16 is selected.



Push 

◇ Call channel

- ① Push and hold [16•C] for 1 sec. to select call channel.
- ② Push [DIAL] to return to the condition before selecting call channel, or push [▲] or [▼] to select operating channel.



Push  for 1 sec.

◇ U.S.A. and International channels

- ① Push [DIAL] to select regular channel.
- ② While pushing and holding [H/L], push [DIAL] to select channel group.
 - U.S.A. or International can be selected in sequence.

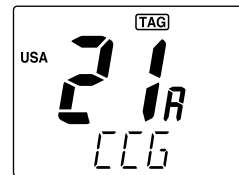

U.S.A. channels

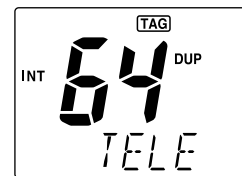
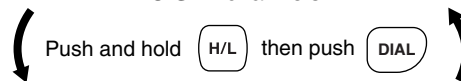

International channels

■ Receiving and transmitting

- ① Push [PWR] to turn power ON.
- ② Push [VOL], then [▲]/[▼] to adjust audio output level.
 - Push [SQL], then [▲]/[▼] to mute any audio noise, if necessary.
- ③ Push [▲]/[▼] to select the desired channel.
 - When receiving a signal, “**BUSY**” appears and audio is emitted from the speaker.
 - Further adjustment of audio level may be necessary at this point.
 - Use the optional voice scrambler function for privacy. (pgs. 10, 35)
- ④ Push [H/L] to select the output power, if necessary.
 - “LOW” appears when low power is selected.
 - Choose low power for shorter, high power for longer distance communications.
 - Some channels are low power only.

- ⑤ Push and hold [PTT] to transmit, then speak into the microphone.
 - “**TX**” appears.
 - Channel 70 cannot be used for transmission (for GMDSS use).
- ⑥ Release [PTT] to receive.

IMPORTANT: To maximize the readability of your transmitted signal (voice), pause a few sec. after pushing [PTT], hold the microphone 10 to 15 cm (4 to 6 inches) from your mouth and speak at a normal voice level.

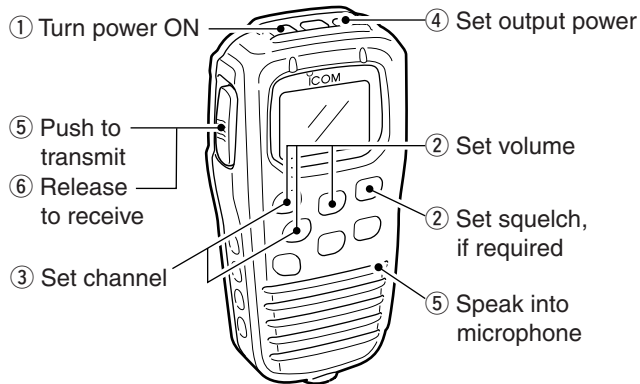

■ Lock functions

The lock function electronically locks keys and switches to prevent accidental changes and function access from the microphone.

• All keys, switches and controllers on the transceiver are functional.

◇ Activating the lock function

➔ While pushing and holding [H/L], push [SQL] to turn the lock function ON and OFF.

- “**L**” appears.
- Only [PWR], [PTT], [H/L], [SQL•MONI], [VOL]+[▲]/[▼] and [SQL]+[▲]/[▼] are functional.

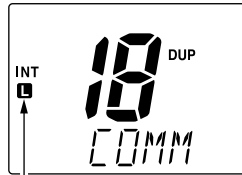

Appears when the lock function is in use.

◇ Activating the all key lock function

➔ While pushing and holding [H/L], turn the power ON by pushing [PWR] to turn the all key lock function ON and OFF.

- “**L**” flashes.
- Only [PWR] and [PTT] are functional.

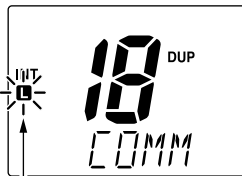

Flashes when the all lock function is in use.

■ Display backlighting

The function display and switches can be backlit for better visibility under low light conditions. And the backlighting condition can be adjusted independently from the transceiver.

- ① Push and hold [VOL•DIM] for 1 sec. to enter backlight adjusting mode.
 - “**DIM**” with number of backlight level appears in the channel name indicator.
- ② Push [▲]/[▼] to adjust the backlight level.
 - The backlight level is adjustable between 0 (lights OFF) and 3 (brightest).

■ Monitor function

The monitor function releases the noise squelch mute of the microphone only. (An independent noise squelch system is employed.)

- ➔ Push and hold [SQL•MONI] for 1 sec. to activate the monitor function.
- “**BUSY**” flashes and audio is emitted.
 - Any key, except [▲]/[▼], cancels the monitor function.

■ Call channel programming

- ① While pushing and holding [H/L], push [DIAL] several times to select the desired channel group (USA or INT) to be programmed.
- ② Push and hold [16•C] for 1 sec. to select the call channel of the selected channel group.
 - “CALL” and call channel number appear.
- ③ Push and hold [16•C] again for 3 sec. (until long beep changes to 2 short beeps) to enter call channel programming condition.
 - Call channel number and channel group to be programmed flashes.
- ④ Push [▲]/[▼] to select the desired channel.
- ⑤ Push [16•C] to program the displayed channel as the call channel.
 - The call channel number and channel group stop flashing.

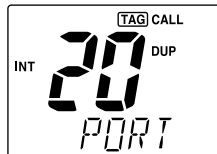
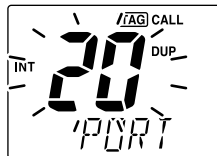
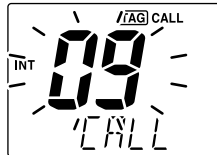

■ Optional voice scrambler operation

◆ Activating the scrambler

- ① Select an operating channel, other than Channel 16.
- ② While pushing and holding [H/L], push [DUAL] to turn the voice scrambler function ON.
 - “SCRM” appears.
- ③ To turn the scrambler function OFF, repeat step ②.
 - “SCRM” disappears.



Appears when the voice scrambler function is in use.

◆ Programming scramble codes

There are 128 codes (00 to 127) available with UT-98 or 32 codes (01 to 32) available with the UT-112 for programming. In order to understand one another, all transceivers in your group must have the same scrambler code, as well as the same scrambler unit. The scrambler code is programmed in set mode. See pgs. 10, 16, 37 for details.

■ Starting a scan

- ① While pushing and holding [H/L], push [DIAL] several times to select the channel group (USA or INT), if desired.
- ② Push [SCAN] to start priority or normal scan.
 - “SCAN” appears during normal scan.
 - The priority channel readout indicates “16”, and “P” and “SCAN” indicators appear during priority scan.
 - When a signal is received, scan pauses until the signal disappears or resumes after pausing 5 sec. according to set mode setting (Channel 16 is still monitored during priority scan).
 - Push [▲]/[▼] to check the scanning tag channels, to change the scanning direction or resume the scan manually.
- ③ To stop the scan, push [SCAN].
 - “SCAN” disappears.
 - Pushing [PTT], [16•C] or [DIAL] also stops the scan.

■ Setting tag channels

- ① While pushing and holding [H/L], push [DIAL] several times to select the channel group (USA and INT), if desired.
- ② Push [▲]/[▼] to select the desired channel to set as a tag channel.
- ③ Push and hold [SCAN•TAG] for 1 sec. to set the displayed channel as a tag channel.
 - “TAG” appears.
- ④ To cancel the tag channel setting, push and hold [SCAN•TAG] for 1 sec.
 - “TAG” disappears.

•Clearing all tag channels in the selected channel group

- ➔ While pushing and holding [H/L], push [SCAN•TAG] for 3 sec. to clearing all tag channels. (until long beep changes to 2 short beeps)

■ Dualwatch/Tri-watch operation

- ① Push [▲]/[▼] to select the desired channel.
 - While pushing and holding [H/L], push [DIAL] several times to select the channel group (USA, INT), if desired.
- ② Push [DUAL] to start dualwatch or tri-watch.
 - “DUAL” appears during dualwatch; “TRI” appears during tri-watch.
 - Beep tone sounds when a signal is received on Channel 16.
 - Tri-watch becomes dualwatch when receiving a signal on the call channel.
- ③ To cancel dualwatch/tri-watch, push [DIAL] again.

■ Set mode programming

Set mode is used to change the condition of the transceiver's functions and the microphone's own functions:

Transceiver's functions—

Scan mode (normal or priority), scan resume timer, dual-watch/tri-watch selection, beep tone function, internal speaker, LCD contrast, scrambler code, scrambler type and ATIS check.

Microphone's own functions—

Beep tone function, LCD contrast and internal speaker.

In this section, instructions are for the microphone's own functions only. Refer to pgs. 14–16 for the setting of the other functions. (Some functions may not be selectable from the microphone.)

◇ Entering set mode

- ① Turn power OFF.
- ② While pushing and holding [16•C], turn power ON.
 - After beep emission, a set mode item (in the channel name indicator and condition in the channel number readout) is displayed.
- ③ Push [16•C] to select the desired item, if necessary.
- ④ Push [▲]/[▼] to select the desired condition of the item.
- ⑤ Turn power OFF, then ON to exit set mode.

• Beep tone “BEEP”

➔ Push [▲] to turn ON, [▼] to turn OFF the beep output.

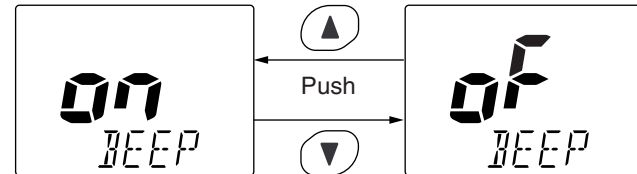

• LCD contrast “LCD CONTRAST”

➔ Push [▲]/[▼] to adjust to a suitable LCD contrast.

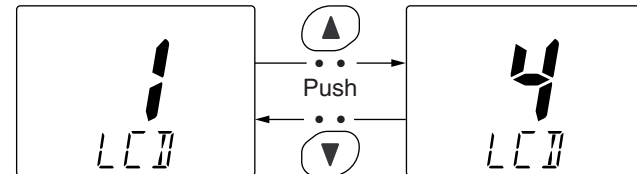

• Internal speaker “INT-SPEAKER”

➔ Push [▲]/[▼] to turn the HM-134 internal-speaker ON/OFF.

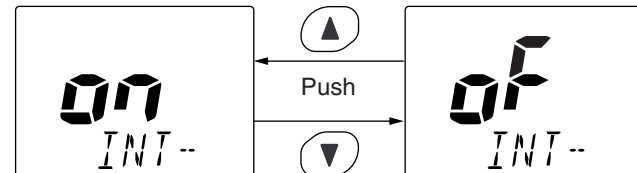

■ Intercom operation

- ① Push and hold [DUAL] for 1 sec. to activate the intercom function.
 - "IC" appears in the priority channel readout.
 - The channel name disappears.
- ② Push [PTT] to talk.
 - "TRLK" appears in the channel name indicator.
- ③ Release [PTT] to listen.
 - "LISTN" appears in the channel name indicator when the transceiver is in talking mode.
- ④ Push [DUAL] to cancel the intercom function.
 - Pushing [16], [SCAN•TAG] or [DIAL] is also cancels the intercom function.

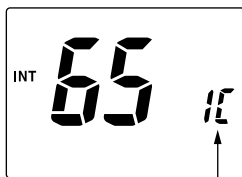

Appears when the intercom function is in use.

For your reference:

In case the intercom mode is selected with the transceiver during microphone power OFF, the microphone power is automatically turned ON and the intercom mode is selected.

◆ Intercom beep function

- ➡ Push and hold [DIAL] for more than 1 sec.
 - Emits intercom beep while holding.

■ Channel names

- ① Push [▲]/[▼] to select a channel to program.
 - While pushing and holding [H/L], push [DIAL] several times to select the channel group (USA and INT), if desired.
- ② While pushing and holding [H/L], push [16•C].
 - The 1st character of the currently programmed comment flashes.
- ③ Push [▲]/[▼] to select a character.
- ④ Push [SQL] to move to right; then push [▲]/[▼] to select a character.
 - Push [VOL] to move to the left.
- ⑤ Continue until the desired characters have been selected, then push [16•C] to return to normal operation.

• Available characters

(space)	! (!)	" (")	# (#)	\$ (\$)	% (%)	& (&)	' (')	((())) ())
* (*)	+ (+)	, (,)	-- (-)	\ (.)	/ (/)	0 (0)	1 (1)	2 (2)	3 (3)
4 (4)	5 (5)	6 (6)	7 (7)	8 (8)	9 (9)	A (A)	B (B)	C (C)	D (D)
E (E)	F (F)	G (G)	H (H)	I (I)	J (J)	K (K)	L (L)	M (M)	N (N)
O (O)	P (P)	Q (Q)	R (R)	S (S)	T (T)	U (U)	V (V)	W (W)	X (X)
Y (Y)	Z (Z)	a (a)	b (b)	c (c)	d (d)	e (e)	f (f)	g (g)	h (h)
i (i)	j (j)	k (k)	l (l)	m (m)	n (n)	o (o)	p (p)	q (q)	r (r)
s (s)	t (t)	u (u)	v (v)	w (w)	x (x)	y (y)	z (z)		

HM-134 CONNECTIONS AND INSTALLATION 13

■ HM-134 supplied accessories

Accessories included with the HM-134:	Qty.
① Connection cable (OPC-1000: 6 m; 20 ft)	1
② Mounting base	1
③ Microphone hanger	1
④ Screws (M3 × 16; tapping)	5

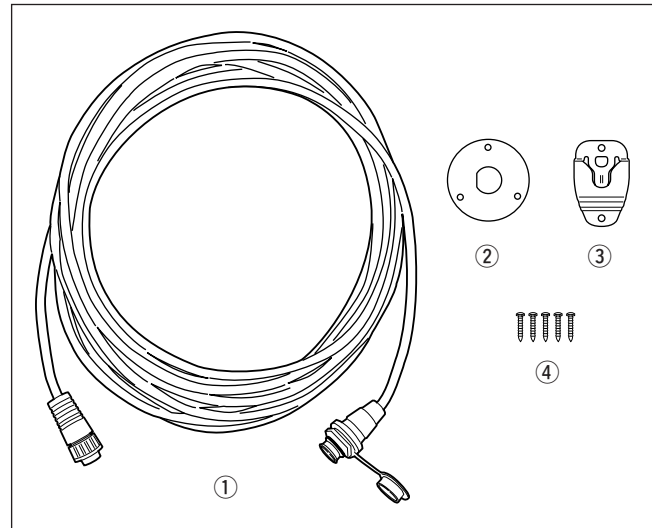

■ Installation

The optional HM-134 can be connected to the transceiver directly, as well as via the supplied connection cable for longer distance remote operation. The connector of the connection cable can be installed into a cabinet, wall, etc., as a built-in plug.

For longer distance remote operation, the optional extension cable, OPC-999 (6 m; 20 ft/Connecting between transceiver and the connection cable.), is available, and up to 2 OPC-999 can be added.

- ① Insert the supplied cable into the external microphone jack and tighten the cable nut as shown below.

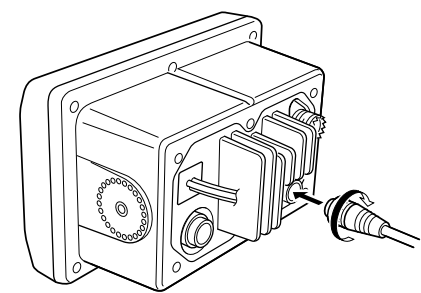

13 HM-134 CONNECTIONS AND INSTALLATION

- ② To use the supplied cable as a wall socket, see the following steps.
- ③ Using the mounting base, carefully mark off the 2 spots where the cable and screws will be fastened.
- ④ Drill holes at these marks.
- ⑤ Install the mounting base using screws as shown below.

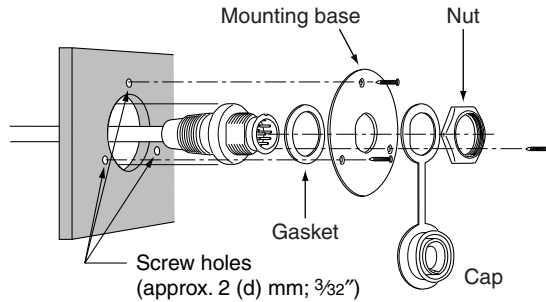

- ⑥ The installation is completed.

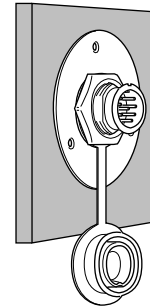

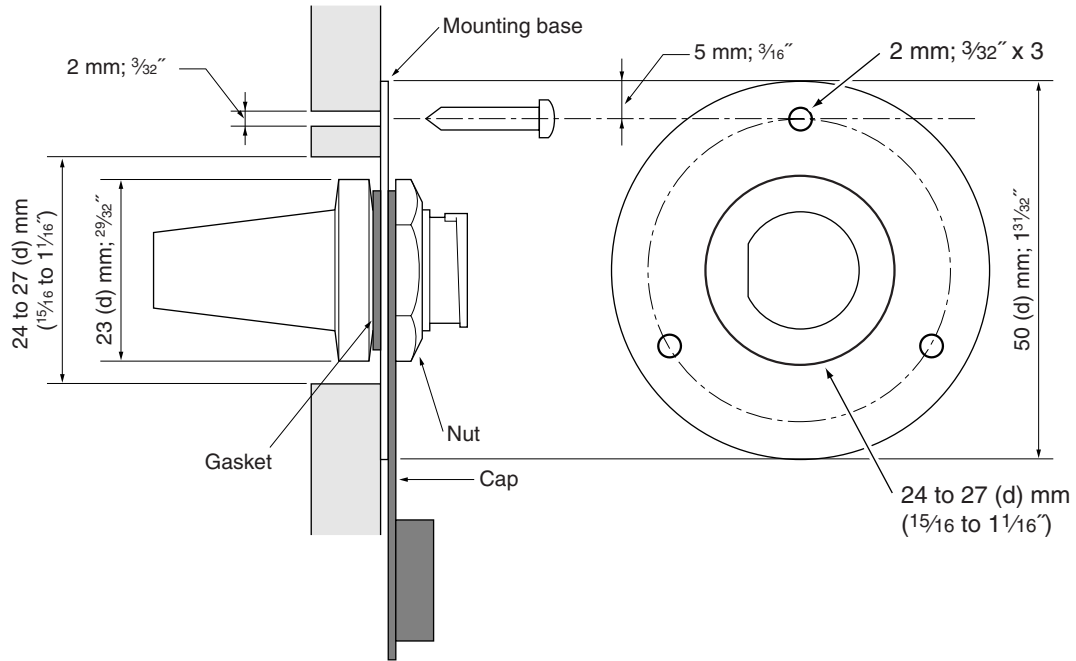

MB-75 TEMPLATE

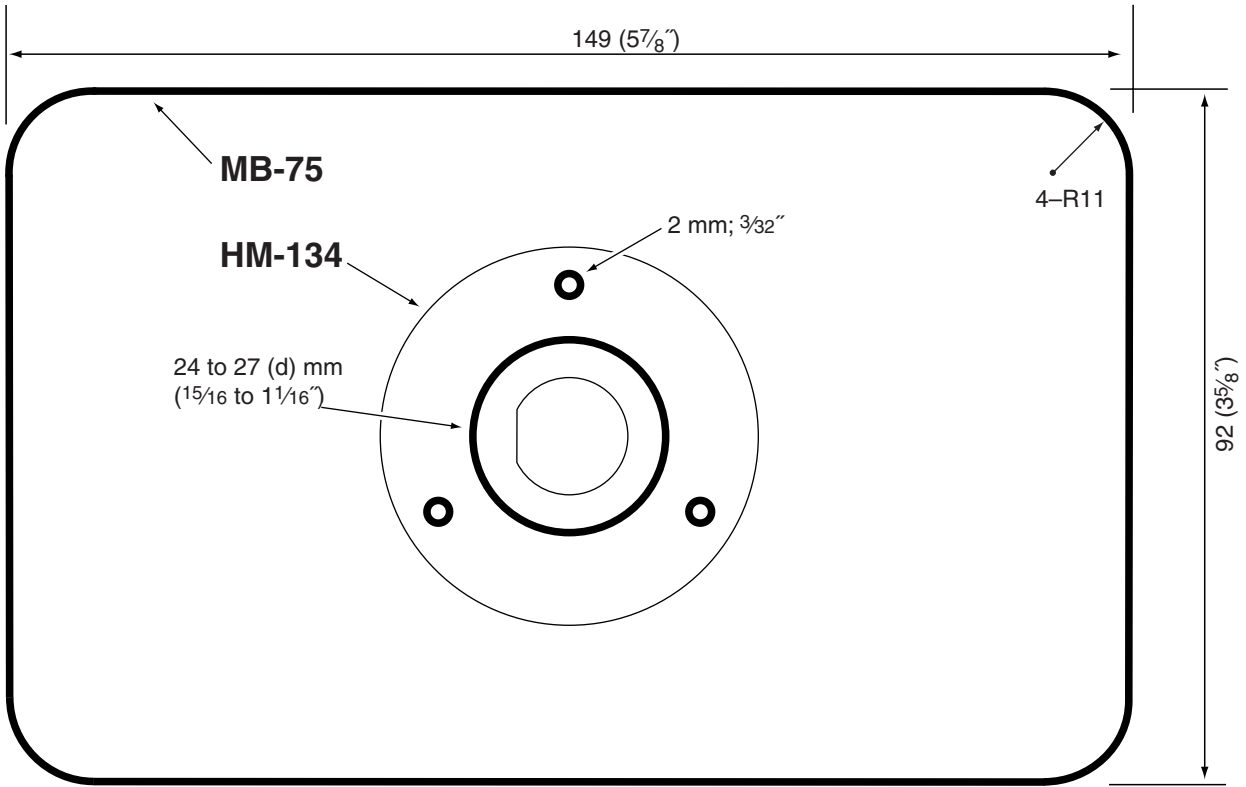

Cut here

Unit: mm (inch)

■ Installation notes

The installation of this equipment should be made in such a manner as to respect the EC recommended electromagnetic field exposure limits (1999/519/EC).

The maximum RF power available from this device is 25 watts. The antenna should be installed as high as possible for maximum efficiency and that this installation height should be at least 5 meters above ground (or accessible) level. In the case where an antenna cannot be installed at a reasonable height, then the transmitter should neither be continuously operated for long periods if any person is within 5 meters of the antenna, nor operated at all if any person is touching the antenna.

In all cases any possible risk depends on the transmitter being activated for long periods. (actual recommendation limits are specified as an average of 6 minutes) Normally the transmitter is not active for long periods of time. Some radio licenses will require that a timer circuit automatically cuts the transmitter after 1–2 minutes etc.

Similarly some types of transmitter, SSB, CW, AM, etc. have a lower 'average' output power and the perceived risk is even lower.



DECLARATION OF CONFORMITY

We Icom Inc. Japan
1-1-32 Kamiminami, Hirano-ku,
Osaka 547-0003 Japan

CE 0560 !

Declare on our sole responsibility that this equipment complies with the essential requirements of the Radio and Telecommunications Terminal Equipment Directive, 1999/5/EC, and that any applicable Essential Test Suite measurements have been performed.

Düsseldorf 25th Sept. 2001

Place and date of issue

Kind of equipment: VHF MARINE TRANSCEIVER

Type-designation: IC-M503

Icom (Europe) GmbH
Himmelgeister straÙe 100
D-40225 Düsseldorf

Authorized representative name

Version (where applicable):

This compliance is based on conformity with the following harmonised standards, specifications or documents:

T. Maebayashi
General Manager

- | | |
|---------------------------|-------------------------|
| i) <u>EN 301 025-1</u> | <u>V1.1.2 (2000-08)</u> |
| ii) <u>EN 301 025-2</u> | <u>V1.1.1 (2000-08)</u> |
| iii) <u>EN 301 025-3</u> | <u>V1.1.1 (2001-05)</u> |
| iv) <u>EN 300 162-2</u> | <u>V1.1.2 (2000-12)</u> |
| v) <u>EN 300 162-3</u> | <u>V1.1.1 (2001-05)</u> |
| vi) <u>EN 60945</u> | <u>1997</u> |
| vii) <u>EN 60950</u> | <u>1992</u> |
| viii) <u>EN 300 698-2</u> | <u>V1.1.1 (2000-8)</u> |

Signature

Icom Inc.

Count on us!

< Intended Country of Use >

- | | | | |
|------------------------------|------------------------------|------------------------------|------------------------------|
| <input type="checkbox"/> GER | <input type="checkbox"/> FRA | <input type="checkbox"/> ESP | <input type="checkbox"/> SWE |
| <input type="checkbox"/> AUT | <input type="checkbox"/> NED | <input type="checkbox"/> POR | <input type="checkbox"/> DEN |
| <input type="checkbox"/> GBR | <input type="checkbox"/> BEL | <input type="checkbox"/> ITA | <input type="checkbox"/> FIN |
| <input type="checkbox"/> IRL | <input type="checkbox"/> LUX | <input type="checkbox"/> GRE | <input type="checkbox"/> SUI |

10 CHANNEL LIST

• International channels

CH	Frequency (MHz)		CH	Frequency (MHz)		CH	Frequency (MHz)		CH	Frequency (MHz)		CH	Frequency (MHz)		CH	Frequency (MHz)	
	Transmit	Receive		Transmit	Receive		Transmit	Receive		Transmit	Receive		Transmit	Receive		Transmit	Receive
01	156.050	160.650	11	156.550	156.550	21	157.050	161.650	62	156.125	160.725	72	156.625	156.625	82	157.125	161.725
02	156.100	160.700	12	156.600	156.600	22	157.100	161.700	63	156.175	160.775	73	156.675	156.675	83	157.175	161.775
03	156.150	160.750	13	156.650	156.650	23	157.150	161.750	64	156.225	160.825	74	156.725	156.725	84	157.225	161.825
04	156.200	160.800	14	156.700	156.700	24	157.200	161.800	65	156.275	160.875	75†	156.775	156.775	85	157.275	161.875
05	156.250	160.850	15†	156.750	156.750	25	157.250	161.850	66	156.325	160.925	76†	156.825	156.825	86	157.325	161.925
06	156.300	156.300	16	156.800	156.800	26	157.300	161.900	67	156.375	156.375	77	156.875	156.875	87	157.375	157.375
07	156.350	160.950	17†	156.850	156.850	27	157.350	161.950	68	156.425	156.425	78	156.925	161.525	88	157.425	157.425
08	156.400	156.400	18	156.900	161.500	28	157.400	162.000	69	156.475	156.475	79	156.975	161.575			
09	156.450	156.450	19	156.950	161.550	60	156.025	160.625	70†	156.525	156.525	80	157.025	161.625			
10	156.500	156.500	20	157.000	161.600	61	156.075	160.675	71	156.575	156.575	81	157.075	161.675			

• USA channels (for U.K. version only)

CH	Frequency (MHz)		CH	Frequency (MHz)		CH	Frequency (MHz)		CH	Frequency (MHz)		CH	Frequency (MHz)		CH	Frequency (MHz)	
	Transmit	Receive		Transmit	Receive		Transmit	Receive		Transmit	Receive		Transmit	Receive		Transmit	Receive
01A	156.050	156.050	12	156.600	156.600	22A	157.100	157.100	64A	156.225	156.225	77	156.875	156.875	86	157.325	161.925
--	---	---	13†	156.650	156.650	23A	157.150	157.150	65A	156.275	156.275	78A	156.925	156.925	86A	157.375	157.325
03A	156.150	156.150	14	156.700	156.700	24	157.200	161.800	66A	156.325	156.325	79A	156.975	156.975	87	157.375	161.975
--	---	---	15†	156.750	156.750	25	157.250	161.850	67†	156.375	156.375	80A	157.025	157.025	87A	157.375	157.375
05A	156.250	156.250	16	156.800	156.800	26	157.300	161.900	68	156.425	156.425	81A	157.075	157.075	88	157.425	162.025
06	156.300	156.300	17†	156.850	156.850	27	157.350	161.950	69	156.475	156.475	82A	157.125	157.125	88A	157.425	157.425
07A	156.350	156.350	18A	156.900	156.900	28	157.400	162.000	70†	156.525	156.525	83A	157.175	157.175			
08	156.400	156.400	19A	156.950	156.950	37A	157.850	157.850	71	156.575	156.575	84	157.225	161.825			
09	156.450	156.450	20	157.000	161.600	61A	156.075	156.075	72	156.625	156.625	84A	157.225	157.225			
10	156.500	156.500	20A	157.000	157.000	--	---	---	73	156.675	156.675	85	157.275	161.875			
11	156.550	156.550	21A	157.050	157.050	63A	156.175	156.175	74	156.725	156.725	85A	157.275	157.275			

†Low power only.

‡Receive only.